

# CAD-805

*50 Watt/Channel Pure Class A Single-Ended Mono Blocks*



*Because You Love the Music.*

**CARY**  
*Audio Design*



# **CAD-805**

## **Single-Ended, Mono Block Amplifier**

### **OPERATING MANUAL**

**Before installing your new CAD-805, please read this manual carefully as it will inform you of the CAD-805's specifications, proper installation and operation procedures. Also included in this manual are guidelines on how to properly service and care for your new CAD-805.**

**December 1995**

## SPECIFICATIONS

Operating the CAD-805 mono-block amplifier is a simple procedure since each unit is designed for long term stability in virtually any home operating situation. Therefore, if the unit is operated outside the parameters outlined in this owner's manual, damage may result. Please read this manual carefully before operating your new CAD-805 amplifier.

### 1.1 Caution Terms

When the following cautionary terms are used in this manual, these definitions apply:

**WARNING:** Electrical hazard! Misuse or failure to follow instructions properly may result in personal injury or death!

**CAUTION:** No risk or personal injury; however, misuse or failure to follow instructions may result in damage to equipment.

**NOTE:** No risk of personal injury or equipment damage; however, misuse or failure to follow instructions may prevent proper performance to the equipment.

### 1.2 Specifications

This section describes the basic specifications of the CAD-805 at the time of printing. Specifications are subject to change without notice or obligation.

<b>POWER OUTPUT:</b>	50W Class A, Single-Ended
<b>FEEDBACK:</b>	0 to 10dB
<b>FREQUENCY RESPONSE:</b>	20 to 20 kHz $\pm$ .5dB
<b>DIMENSIONS:</b>	10"H x 12-1/4"W x 24"D
<b>INPUT POWER REQUIREMENTS:</b>	100, 110, 117, 220, 240, / 50-60Hz
<b>NET WEIGHT:</b>	80 lbs.
<b>POWER CONSUMPTION:</b>	230 watts - OPERATE, 76 watts - STANDBY
<b>SHIPPING WEIGHT:</b>	105 lbs.
<b>INPUT IMPEDANCE:</b>	150,000 ohms
<b>OUTPUT IMPEDANCE:</b>	4, 8 and 16 ohms

<b>NOISE:</b>	80dB below rated output
<b>SENSITIVITY:</b>	1V @ zero feedback for full output
<b>COUPLING CAPACITORS:</b>	oil filled
<b>POWER SUPPLY CAPACITORS:</b>	4-1500 MFD @ 450V
<b>TRANSFORMERS:</b>	1-Ellaminated core power transformer 1-special air-gap output transformer 200% duty cycle on all transformers
<b>TUBE COMPLIMENT:</b>	1-6SL7 per mono-block 1-300B per mono-block 1-211 per mono-block
<b>WARM-UP TIME:</b>	5 minutes
<b>BREAK-IN PERIOD:</b>	100 hours of music playing time
<b>FINISH:</b>	textured black
<b>AC CORD:</b>	3 conductor shielded and detachable

### 1.3 Front Panel Features

**EYE TUBE:** Indicates power output. When the eye is completely closed the amplifier is at full output.

### 1.4 Top Panel Features

**OFF-ON ROCKER SWITCH:** Turns AC power on in the rear position. The 211 tube will not light at this point.

**STAND BY:** Turns the filament of the 211 on in the rear position.

**FEEDBACK LEVEL:** Adjusts the level of feedback from 0 to 10dB

**FEEDBACK OUTPUT:** Selects output for feedback when feedback level is above zero. This should be set on the output in use 4,8 or 16 ohm.

## 1.5

### Rear Apron Features

<b>INPUT:</b>	Signal input connection via shielded interconnect cable
<b>OUTPUT:</b>	Three 5-way copper binding posts provide output to the speaker system (4, 8 or 16 ohm).
<b>FUSE:</b>	AC power fuse. Never replace with any other valve than 3 AMP SLOW BLOW! 250 VOLT!
<b>TUBE FUSE:</b>	Never replace with any other fuse than 1/2 amp FAST BLOW!

## INSTALLATION

This section describes the unpacking and installation procedures for the CAD-805 amplifier.

### 2.1 Unpacking

All shipping containers have been specially designed to protect their contents and special care has been taken to prevent damage under normal shipping conditions. Mishandling should be evident upon inspection of the shipping container. If damage is found after visual inspection, take care not to destroy the evidence. If necessary, document the damage with photographs and contact the transport carrier immediately.

Carefully remove your new CAD-805 from its packing carton and examine it closely for signs of shipping damage. It is recommended to save all original packing cartons to protect your preamplifier from damage should you wish to store it or ship it for after-sales service.

### 2.2 Warranty Card

If you were the original purchaser of this unit and you purchased it in the United States, you should fill out the enclosed warranty registration card and return it to Cary Audio Design within 10 days of your purchase. Cary Audio Design also suggests that you keep your original packing cartons in case you need to ship the unit. Warranty restrictions apply. Consult the warranty section of this manual for details.

### 2.3 CAD-805 Placement

The CAD-805 is designed for use inside homes. It must be protected from the elements and temperature extremes. For example, avoid placing the unit in extremely hot locations such as near radiators or other heating units. Its location among the user's audio components is not critical; however, certain precautions must be taken.

### 2.4 Power Requirements

The CAD-805 is designed to operate from house current mains. The design voltage is 117 VAC at 50/60Hz (Foreign units 234 VAC at 50/60Hz).

## 2.5 Cables

The speaker cables from the output posts of the CAD-805 to the speaker system can be any convenient length your set-up requires. Select speaker cables of sufficient size to preserve the outstanding performance capabilities of your CAD-805. Heavy gauge #16 wire is suitable for distances up to 10 feet; #12 for 25 feet. Most audio dealers will have proper speaker cable in stock for this purpose.

## 2.6 Interconnects

Signal input connect is made via the input jack on the rear of the CAD-805 located next to the output binding posts. The interconnect cables from the output of the preamplifier can be any convenient length your set-up requires. The choice of a high quality interconnect cable is important. Once again, your audio dealer will have the proper cables in stock for this purpose.

## OPERATION

Your new CAD-805 is ready for operation after the speaker, interconnect cables and three tubes have been installed. See pages 8 and 9 for tube positions. **FAILURE TO INSTALL TUBES CORRECTLY WILL DAMAGE THE UNIT.**

### 3.1 Off-On Power Switch

Simply push the AC rocker switch toward the rear of the "ON" position. The 6SL7, 6U5 and 300B tube will light.

### 3.2 Stand-By Switch

Push the rocker switch toward the rear of the unit to operate. The 211 tube will light.

### 3.3 Break In Period

The tubes, capacitors and output transformers take approximately 100 hours of music playing to fully settle in for peak performance. The CAD-805s may seem sterile or thin sounding right out of the box. After the first couple of hours you will notice increased depth and tighter bass. This break in period defies all engineering theory, but is true with most audio amplifiers.

## SERVICE AND CARE

The CAD-805 chassis may be cleaned with a soft towel and Windex® (or a similar window cleaner). The frequency of cleaning will be governed by the number of hours the CAD-805 is operated and by operating environmental cleanliness.

### 4.1 Tube Replacement

If it becomes necessary to replace the tubes in the CAD-805, the same brand should be used. A new tube kit is available from Cary Audio Design. Although tube life varies depending on the nature and degree of use. Under normal operating condition for home use, the 211 output tube and the 300B driver tube should last many years in the CAD-805. The 6SL7 input tube should last even longer.

## **WARNING**

**Make sure amplifier is unplugged from AC mains**

### **4.2 Factory Service**

Careful consideration has been given to the design of your CAD-805 to keep maintenance problems to a minimum; however, it is possible that some problems may arise which cannot be cured by tube substitution. After reading the Troubleshooting Guide at the end of this manual, we suggest that you contact our Customer Service Department at phone number (919) 481-4494 to describe your problem in detail. **Do not return the CAD-805 to the factory without a Return Authorization Number from the Customer Service Department.** Cary Audio Design will assume no responsibility if the transportation company refuses to pay damage claim due to your improper packing or lack of insurance should the unit be lost in shipment.

### **Non-Warranty Repairs**

Cary Audio Design will provide repair service for its products charging on a time and expense basis for the repairs.

## **WARNINGS**

**Make no attempt to put the CAD-805 in service outside of the cabinet - Contact with high voltages found in the unit can be fatal!!!**

**Completely remove AC power plug from the wall and allow 30 minutes for the high voltage capacitors to discharge through bleeder resistors before attempting to change tubes or clean the inside to the preamplifier.**

## **CAUTIONS**

**Never remove/insert AC plug when the unit is on or the AC power switch is in the "ON" position**

**Obstruction of the top portion of the CAD-805 will result in tubes overheating**

**PROPRIETARY RIGHTS:** Cary Audio Design has proprietary right in the design and components of its units. While the purchaser is entitled to use the unit for its intended purpose, use of the unit for its intended purpose, use of the unit for copying, imitation, or reverse engineering is a violation of these proprietary rights and is forbidden.

# CAD - 805 Bias Adjustment

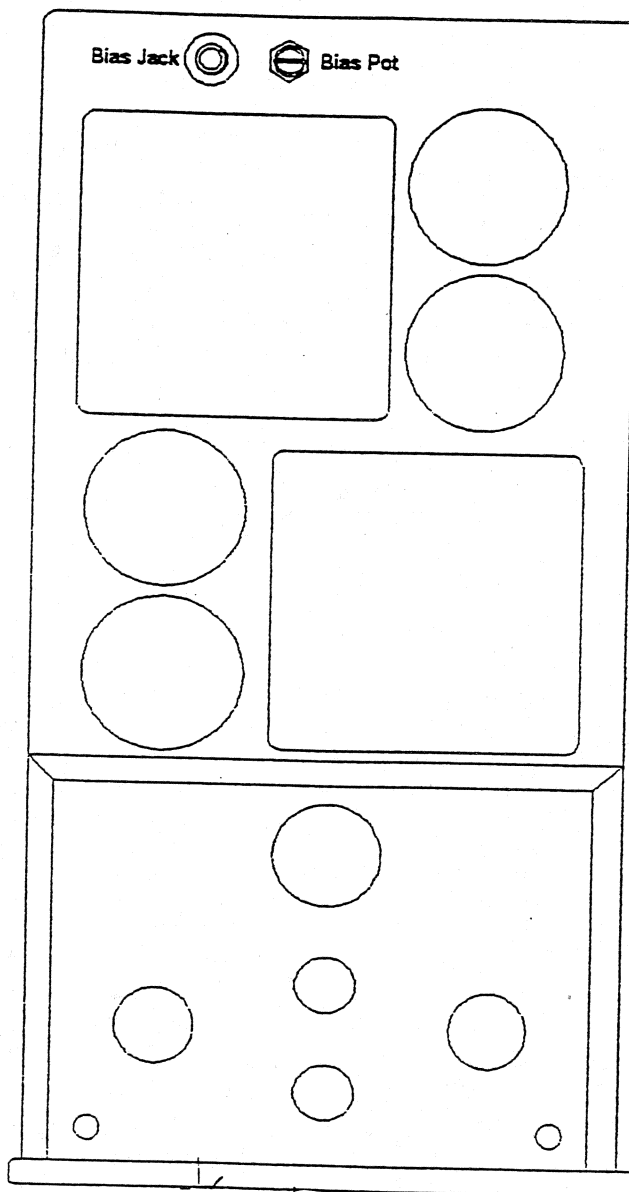
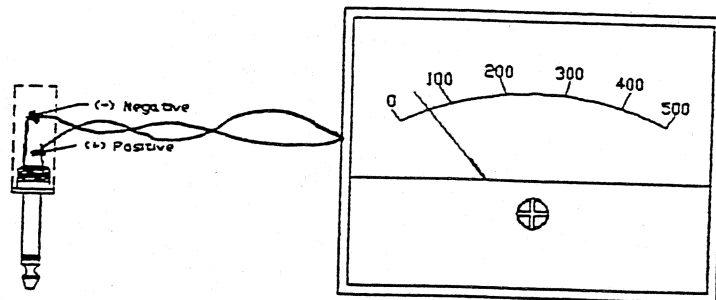

Note: Bias is factory preset; Bias should be reset when installing replacement 300B tubes. The amplifier must be in operate mode to set bias.

Inserting 1/4" meter plug into bias jack. Adjust for 60mA reading on VQM or DC current meter. Readjust to 60mA after 805 is warmed up for 10 minutes. Remove the plug and enjoy the music!



300B  
TUBE

THIS SIDE OF TUBE  
CHIMNEY SHOULD FACE  
TO THE FRONT

PRINT SHOULD FACE  
TO THE FRONT

300 B

LARGE PINS TO  
LARGE HOLES IN  
SOCKET FRONT

RED DOT INDICATES  
LARGE PINS ON TUBE

IMPORTANT!    IMPORTANT!

THE TWO LARGE FINS ON THE BASE  
OF THE 300B TUBES MUST FACE  
THE FRONT OF THE CAD-300 AMPLIFIER!!

RED DOT INDICATES  
LARGE HOLES LOCATION  
AND SOCKET-FRONT SIDE

AMPLIFIER FRONT

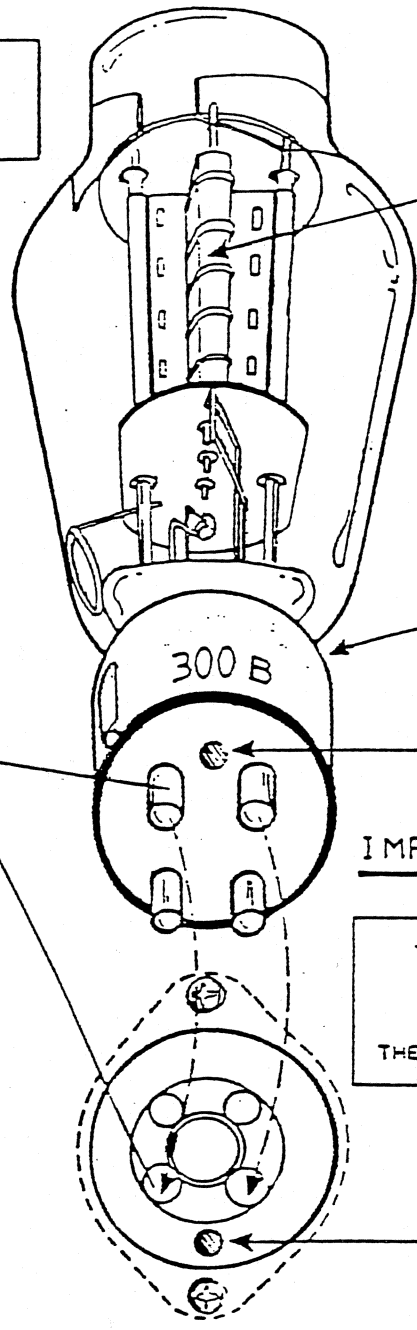

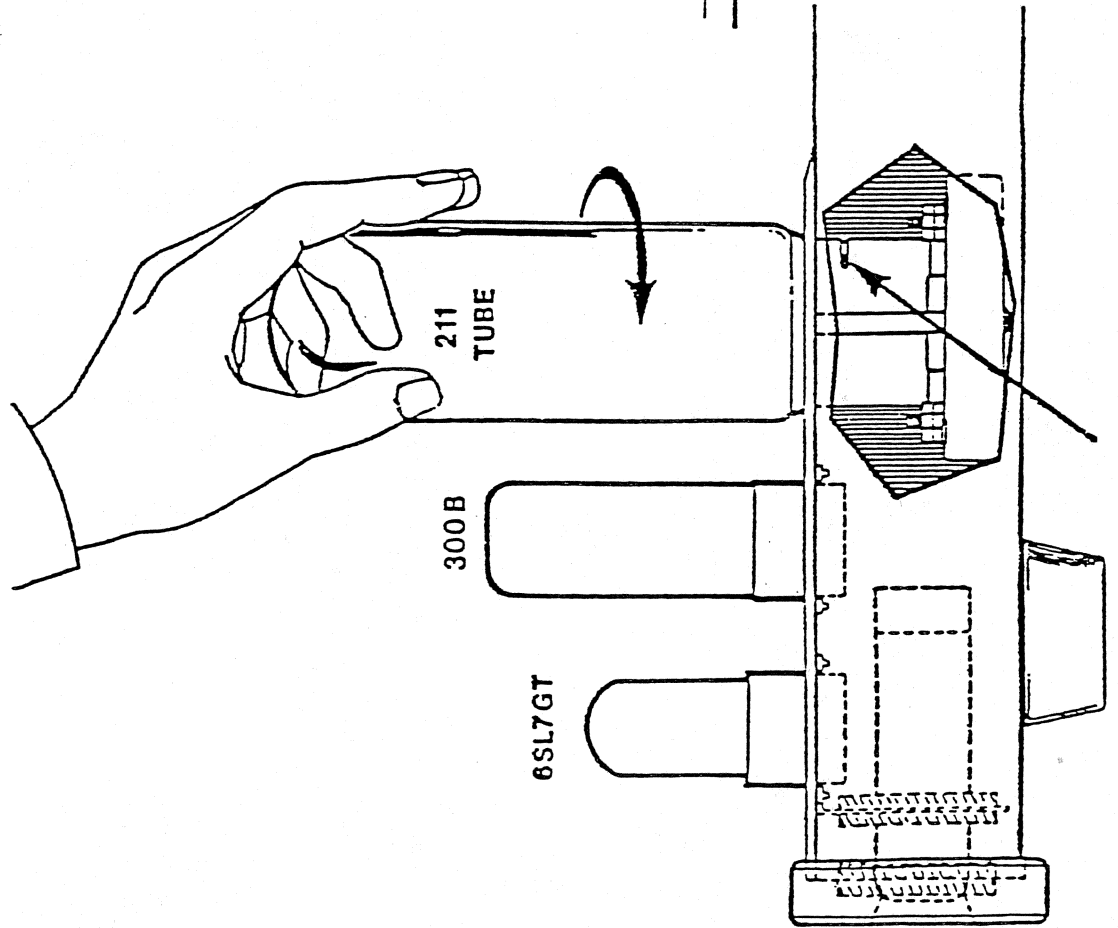
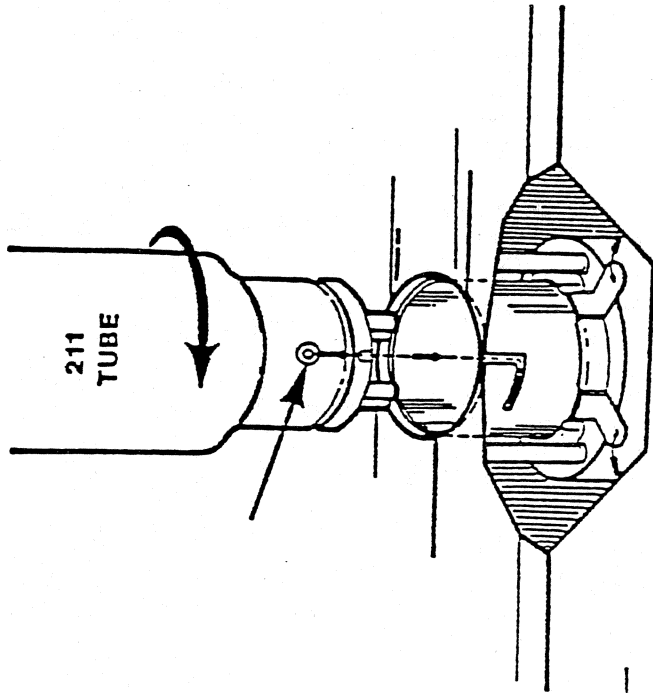

## CAD-805 TROUBLESHOOTING GUIDE

SYMPTOM	CAUSE	REMEDY
Hum or "Buzzing" through speakers	<ul style="list-style-type: none"> <li>- Ground loop</li> <li>- 300B tube with high plate current</li> <li>- Intermittant or poor connection of interconnect ground</li> </ul>	<ul style="list-style-type: none"> <li>-Install 2-pin adapter on A.C. cord to float the ground.</li> <li>- Check bias of 300B. If high, readjust to proper bias setting.</li> <li>- Replace interconnect.</li> </ul>
"Popping or "Spitting" noise through the speaker	<ul style="list-style-type: none"> <li>- Noisy tube</li> </ul>	<ul style="list-style-type: none"> <li>-If noise is in one channel, swap one section of tubes at a time until the noise swaps channels. Replace noisy tube.</li> <li>-Check bias of output tubes. If high or fluctuating rapidly, replace output tube.</li> </ul>
AC fuse blows	<ul style="list-style-type: none"> <li>-Line voltage surge</li> </ul>	<ul style="list-style-type: none"> <li>-Replace fuse.</li> </ul>
Tube fuse blows	<ul style="list-style-type: none"> <li>-Shorted 211 tube</li> </ul>	<ul style="list-style-type: none"> <li>-Replace tube.</li> </ul>