



# CAD-300SE

## OPERATING MANUAL

**NOTE:**

Before installing your new CAD-300SEs, please read this manual carefully. This manual will inform you of the CAD-300SE's specifications, proper installation procedures. Also included in this manual are guidelines on how to properly service and care for your new CAD-300SEs.

## CAD-300SE

### Single Ended Triode Mono Blocks

#### INTRODUCTION

**Congratulations!** You have purchased one of the most exotic vacuum tube audio amplifiers available. Within its power range, the CAD-300SE mono blocks offer the most realistic sound reproduction one could desire for a "high-end" home audio system. Careful design, parts selection and proper circuit topologies contribute to incredible reliability and enjoyment.

For the technically minded, a review of the circuit is in order. Your new CAD-300SE operates in a class A single-ended mode utilizing fixed negative grid voltage on the 300B triode output tube. The input stage utilizes a 6SL7 dual triode wired in a series constant-current plate-loaded configuration. The output transformer in the CAD-300SE is the most important component in the amplifier and has been specifically designed by Cary Audio for use in the 300SEs. The output transformer is an air-gap design with a commercial continuous rating of 200% duty cycle. The 300SE output transformer is an E/I laminate, silicon impregnated, grain oriented steel design. The windings are wax vacuum impregnated and the entire transformer is potted in high temperature wax. Utilizing the linear, directly heated filament-cathode, 300B triode output tube, there is no global feedback used in the CAD-300SE. The power supply is a full wave center tap configuration running a CV-378 (heavy duty 5AR4) vacuum tube rectifier. The rectified 430 VDC is fed to a pi-L filter network. The filter capacitors consist of two (2) 1200 MFD and one (1) 100 MFD computer grade electrolytics for a total of over 230 Joules of energy storage. Each electrolytic capacitor is by-passed with a low impedance .22 polystyrene capacitor. The power transformer is also a 200% duty cycle rating on the CAD-300SE. To avoid AC hum, both the 6SL7 and 300B tubes have DC voltage on the filaments. This will prevent AC ripple voltage from capacitively being coupled to the elements in the tubes.

#### ADDITIONAL DESIGN THOUGHTS

A great deal of attention during design of your new CAD-300SE was concentrated on the "overload recovery" ability of an amplifier to instantly recover from clipping is much more important than is commonly believed. In the power war of amplifier manufacturers the mentality is focused on high and then even higher power output to solve the clipping problem. When in reality the most critical aspect is how fast a recovery and amplifier can achieve after overload. With the incredible dynamic range of live and in turn recorded music even 2000 watts of power is not enough power. Most of the music being listened to in an average listening room is only requiring about 3 watts of power. It is on the transients of loud low frequency program material that tremendous signal voltages will appear at the input of the amplifier. It is in this situation that the overload recovery ability of an amplifier is of critical concern. The single-ended CAD-300SE extols its merits in the ability to handle transients and instantaneously recover from brief or even extended overloads. The CAD-300SEs will overload symmetrically at any frequency in the audio band pass. The 300SEs will also yield faithful reproduction of extremely low frequencies at full output levels. Power transformer, power supply regulation and output transformer design and careful shaping of the overall frequency response curve all play a very important part in the ability of the CAD-300SE to recover quickly when overloaded. If one were to monitor the high voltage rail voltage (420 VDC) of a 300SE during soft and loud music passages it will be found there is no more than a volt or so change from soft to loud passages.

Another technical feature of your new CAD-300SE is amplifier stability. The 300SE may be operated with no load (without speaker) without damage to the amplifier, output transformer or tubes.

The most exciting feature of the CAD-300SE, aside from how compact and gorgeous it looks, is the delightful, sensual beauty of the music it recreates. The first thing that will strike you about your new CAD-300SE amplifiers is the incredible transparency and resolution of detail of the music. The 300SE's sensual nature is best revealed in the sense of life it displays in female vocalists.

Your new CAD-300SE mono blocks presents music with such presence and directness, you'll be drawn into the music hour after a musically satisfying hour. This is the result of single-ended circuit techniques, which eliminate and crossover notch at low levels and also contributes to the freedom from listening fatigue. The 300SEs will draw you in even further as you realize how lucid and utterly uncolored neutrality reveals delicate nuances in the sound stage.

Enjoy the music, and of course, please read this complete manual for a complete understanding of trouble free operation.

### **SPECIFICATIONS**

Operating the CAD-300SE mono block amplifier is a simple procedure since each unit is designed for long term stability in virtually any home operating situation. Therefore, if the unit is operated outside the parameters outlined in this owner's manual, damage may result. Please read this manual carefully before putting your new Cary Audio Design 300SE in operation.

The following definitions are applicable to this manual. These definitions must be followed explicitly.

**WARNING**  
**HAZARD PRESENTS PERSONAL INJURY OR DEATH**

**Caution**  
EQUIPMENT DAMAGE MAY OCCUR BUT NOT PERSONAL INJURY

**Note**  
Proper performance of the amplifier cannot be ensured if disregarded

### **1.2 Specifications**

The following section describes the CAD-300SE basic specs. Specifications are subject to change without notice or obligation.

**DIMENSIONS:** 6"H x 5 1/2"W x 19"D

**WEIGHT:** 24 Lb..

**CIRCUIT TYPE:** Single Ended Amplification in Class A

**POWER OUTPUT:** 1KHz sign wave  
6.5 volts RMS across 4 ohms = 10.5 watts  
9 volts RMS across 8 ohms = 10 watts

**INPUT SENSITIVITY:** 1.1 volts for full output

**INPUT IMPEDANCE:** 150,000 ohms

**NOISE AND HUM:** 80dB below rated output

**FREQUENCY RESPONSE (at one watt output):** 20Hz to 23,000Hz + 0/ - .75dB

**DAMPING FACTOR:** Greater than 35

TUBES: 1-6SL7 input tube, 1-300B Triode output, 1-CV378 Rectifier tube

TRANSFORMERS: 1-EI laminated core power transformer  
1-Special air gap output transformer  
200% duty cycle on all transformers

RESISTORS: 1% metal film

CAPACITORS: Polystyrene and polypropylene

POWER SUPPLY CAPACITORS: 2-1200 MFD 450VDC, 1-100 MFD 450VDC

AC CORD: 3 conductor shielded

AC POWER REQUIREMENTS: 117 volts AC 50/60 Hz  
95 watts operate  
30 watts in stand by (option)  
220 volts AC 50/60 Hz  
95 watts operate  
30 watts in stand by (option)

WARM-UP TIME: 3 minutes

BREAK-IN PERIOD: 100 hours of music playing time

FINISH: Nickel chrome plated stainless steel

### 1.3 Front Panel Features

AC-ON TOGGLE SWITCH: Turns AC power on in the "up" position. Left Blue LED Comes on.

STAND-BY/ OPERATE: Turns B+ high voltage on in the "up" position. Right Blue LED comes on.

### 1.4 Rear Apron Features

INPUT: Signal input connection via shielded interconnect cable

OUTPUT: The 5-way binding posts provide the output to the speaker system. Red = +, Black = -

**CAUTION**  
EQUIPMENT DAMAGE MAY OCCUR WITH IMPROPER FUSES

AC: 3 conductor shielded power cord to AC power mains

**CAUTION**  
USE OF ANY OTHER PROTECTION FUSE CAN DAMAGE UNIT

FUSE: AC power fuse. Never replace with any other valve than 2 AMP  
SLOW BLOW! 250 VOLT

STAND-BY: In the "up" position, the CAD-300SE is in the operate mode.  
In the "down" position, the high voltage B+ power supply is  
turned off and the front panel BLUE LED will not light.

<p style="text-align: center;"><b>CAUTION</b> NEVER REMOVE/ INSERT AC LINE CORD WHEN THE UNIT IS ON</p>
---

**TO INSTALL THE 300B TUBE, REFER TO PAGE 7 OF THIS MANUAL AND READ INSTRUCTIONS CAREFULLY!**

## INSTALLATION

This section describes the unpacking and installation procedures for the CAD-300SE amplifier.

**WARNING**  
**MAKE NO ATTEMPT TO PUT THE CAD-300SE AMPLIFIER IN SERVICE**  
**WITHOUT THE BOTTOM PLATE ATTACHED - CONTACT WITH VOLTAGE**  
**IN THE CAD-300SE CAN BE FATAL!!!**

### **2.2 Unpacking**

All shipping containers have been specifically designed to protect their contents and special care has been taken to prevent damage under normal shipping conditions. Mishandling should be evident upon inspection, take care not to destroy the evidence. If necessary, document the damage with photographs and contact the transport carrier immediately.

Carefully remove your new CAD-300SE amplifier from its packing carton, and examine it closely for signs of shipping damage. It is recommended to save all original packing cartons to protect your amplifier from damage should you wish to store it or ship it for after sales service.

### **2.3 Warranty Card**

Fill out the enclosed warranty registration card and return to Cary Audio Design, Inc. within 10 days of original purchase. Keep your original sales slip with the packing cartons should you ever need it for reference. **Failure to register warranty will limit the warranty to one year.**

### **2.4 Amplifier Placement**

In general, the location of your new CAD-300SE amplifier is not critical. The best placement in your system is near the speaker system with short lengths of speaker cables. Certain precautions must be taken to ensure optimum performance. Avoid extremely hot locations such as near radiators or other heating units. Keep the top of the CAD-300SE clear of books, paper or other equipment to protect against overheating.

## **2.5 Power Requirements**

The CAD-300SE is designed to operate from house current mains. The design voltage is 117VAC at 50/60Hz. (Foreign units 234 VAC at 50/60Hz)

## **2.6 Cables**

The speaker cables from the output posts of the CAD-300SE to the speaker system can be any convenient length your set-up requires. Select speaker cables of sufficient size to preserve the outstanding performance capabilities of your CAD-300SE. Heavy gauge #16 wire is suitable for distances up to 10 feet; #12 for 25 feet. Most audio dealers will have proper speaker cable in stock for this purpose.

## **OPERATION**

Signal input connections is made via the input jack on the rear of the CAD-300SE located next to the output binding posts. The interconnect cables from the output of the preamplifier can be any convenient length your set-up requires. The choice of a high quality interconnect cable is important. Once again, your audio dealer will have the proper cables in stock for this purpose.

### **3.1 Operation**

Your new CAD-300SE's are ready for operation after the speaker, interconnect cables and the three tubes have been installed. See page 7 for tube positions.

### **3.2 AC On Power Switch**

Simply push the AC rocker switch up to the ON position (the BLUE LED will light). The BLUE LED on the front panel will light after about 30 seconds as the B+ high voltage comes up. Observe that all tubes are lit (filaments).

### **3.3 Stand-By Switch**

This is a most convenient feature on the CAD-300SE amplifier. This switch is located on the front of the amplifier. In the "up" position, the amplifier is ready to operate. In the "down" position (provided the front panel AC switch is in the "on" position), only the tube filaments are operating. You may wish to leave your CAD-300SE amp turned on in the stand-by mode 24 hours a day. When you wish to listen to music, simply flip the stand-by switch in the "up" position. Under these conditions the CAD-300SE's are always warmed up and ready for peak performance.

### **3.4 Break In Period**

The tubes, capacitors and output transformers take approximately 100 hours of music playing to fully settle in for peak performance. The CAD-300SE's may seem sterile or thin sounding right out of the box. After the first couple of hours you will notice increased depth and tighter bass. This break in period defies all engineering theory, but is true with most audio amplifiers.

## SERVICE AND CARE

### 4.1 CAD-300SE Care and Cleaning

The chassis of the CAD-300SE may be cleaned with a soft rag and Windex (or a similar window cleaner). The frequency of cleaning will be governed by how many hours the CAD-300SE is operated and by operating environmental cleanliness.

### 4.2 Tube Replacement

If it becomes necessary to replace the tubes in the CAD-300SE amplifier, a matched set of tubes of the same brand should be used. A new tube kit is available from Cary Audio Design, Inc. You should get year's from the 300B output tube with everyday usage and many, many years of use from the 6SL7 input tube and CV378 rectifier tube.

#### **WARNING**

**Make sure amplifier is unplugged from AC mains**

### 4.3 Factory Service

Careful consideration has been given to the design of your CAD-300SEs to keep maintenance problems to a minimum; however, it is possible that some problems may arise which cannot be cured by tube substitution. After reading the Troubleshooting Guide at the end of this manual, we suggest that you contact our Customer Service Department at phone number (919) 481-4494 to describe your problem in detail. **Do not return the CAD-300SE to the factory without a Return Authorization Number from the Customer Service Department.** Cary Audio Design will assume no responsibility if the transportation company refuses to pay damage claim due to your improper packing or lack of insurance should the unit be lost in shipment.

#### **Non-Warranty Repairs**

Cary Audio Design will provide repair service for its products charging on a time and expense basis for the repairs.

#### **WARNINGS**

**Make no attempt to put the CAD-300SE in service outside of the cabinet - Contact with high voltages found in the unit can be fatal!!!**

**Completely remove AC power plug from the wall and allow 30 minutes for the high voltage capacitors to discharge through bleeder resistors before attempting to change tubes or clean the inside to the preamplifier.**

#### **CAUTIONS**

**Never remove/insert AC plug when the unit is on or the AC power switch is in the "ON" position**

**Obstruction of the top portion of the CAD-300SE will result in tubes overheating**

REAR

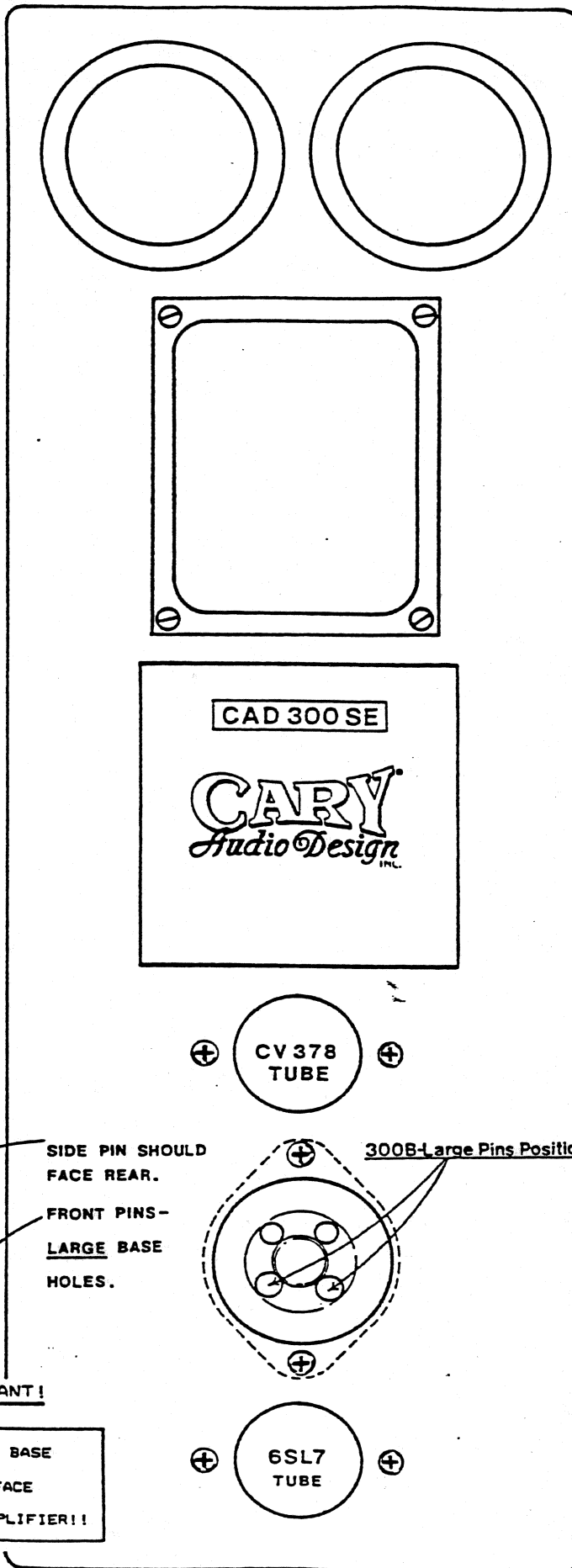

TUBE 300B

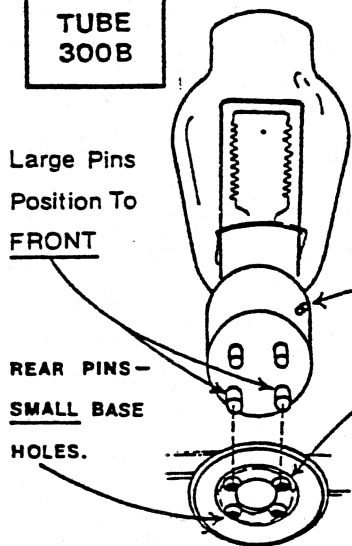

SIDE PIN SHOULD FACE REAR.  
 FRONT PINS - LARGE BASE HOLES.

300B-Large Pins Position In Front

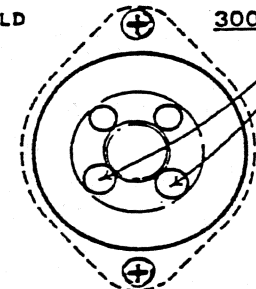

IMPORTANT! IMPORTANT!

THE TWO LARGE PINS ON THE BASE OF THE 300B TUBES MUST FACE THE FRONT OF THE CAD-300 AMPLIFIER!!

FRONT



## 300 SE Bias Adjustment

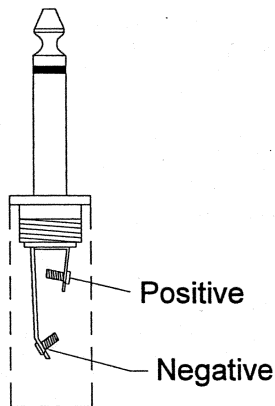
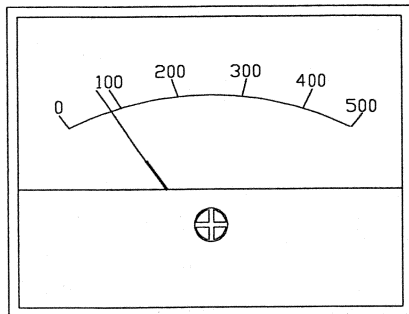
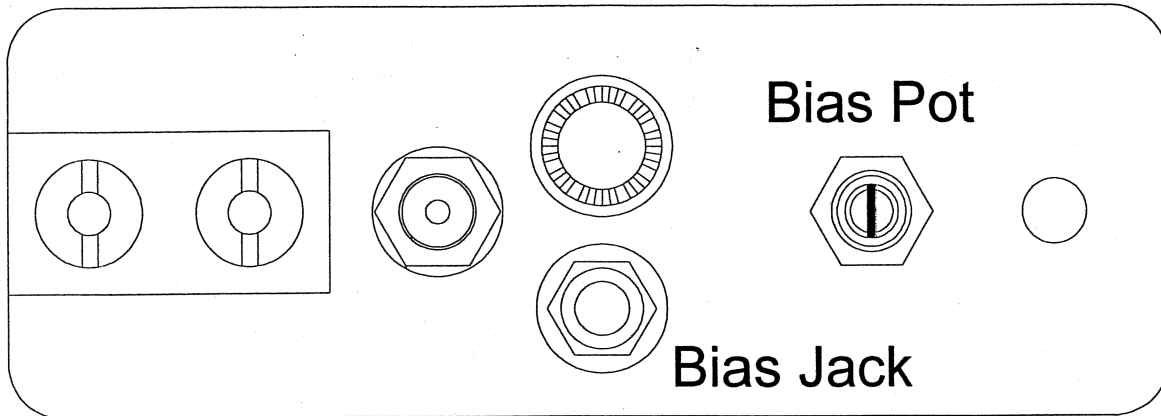

Insert meter plug into bias jack.  
Adjust for 83mA reading on VOM or DC current meter.  
Readjust to 83mA after 300 SE is warmed up for  
10 minutes. Remove plug and enjoy the music!

**Note: Bias is factory preset; Bias should be reset when installing replacement 300B tube.**

## UNITED STATES LIMITED WARRANTY

Cary Audio Design, Inc. warrants to the original United States purchaser for use in the United States, that this product shall be free from defects in material (except tubes and AF output transistors) or workmanship for:

Models CAD-211M, SLM-200 and the CAD-805, Five (5) years from the date of the original purchase.

Amplifiers and Preamplifiers, Three (3) years from the date of the original purchase.

Digital, One (1) year from date of original purchase.

During the warranty period, Cary Audio Design or an authorized Cary Audio Design service facility will provide free of charge both parts (except tubes and AF output transistors) and labor necessary to correct defects in material or workmanship.

To obtain such warranty service, the original purchaser must:

- (1) Complete and send in the warranty Registration Card.
- (2) Notify Cary Audio Designs as soon as possible after the discovery of a possible defect:
  - (a) The model number and serial number;
  - (b) The identity of the seller and the approximate date of purchase;
  - (c) A detailed description of the problem, including details on the electrical connection in the associated equipment and the list of such equipment.
- (3) Deliver the product to Cary Audio Designs or the nearest authorized service facility, or ship the same in its original container or equivalent, fully insured and the shipping charges prepaid.

Correct maintenance, repair and use are important to obtain optimum performance from this product. Therefore, carefully read the Operating Manual. This warranty does not apply to any defect that Cary Audio Design in its sole discretion determines is due to:

- (1) Improper maintenance or repair, including the installation of parts or accessories that do not conform to the quality and the specifications of the original parts.
- (2) Misuse, abuse, neglect or improper installation.
- (3) Accidental or incidental damage.

### WARRANTY DISCLAIMER

Except for the express warranties stated herein, Cary Audio Design disclaims all other warranties including, without limitation, all implied warranties of merchantability and fitness for a particular purpose.

### EXCLUSIVE REMEDY

Notwithstanding the foregoing, the purchaser's exclusive remedy for any breach of warranty, express or implied, is limited to the repair or replacement of the defective unit or the refund of the purchase price, at the option of Cary Audio Design. Under no circumstances is Cary Audio Design liable for incidental or consequential damages. Any implied warranties imposed by law terminate one (1) year from the date of purchase.

### FOREIGN PURCHASERS

Cary Audio Design warrants its merchandise to purchasers in the United States for use in the United States. It provides no other warranties. If you are a foreign purchaser, consult with your dealer to determine whether your dealer provides any warranty.

The foregoing constitutes Cary Audio Design's entire obligation with respect to this product, and the original purchaser and any user or owner shall have no other claim for incidental or consequential damages. Some states do not allow the exclusion or limitation of incidental or consequential damages, so the above limitation and exclusion may not apply to you.

This warranty gives legal rights and you may also have other rights which vary from state to state.



C A R Y • A U D I O • D E S I G N  
111-A WOODWINDS INDUSTRIAL COURT, CARY, N.C. 27511 (919) 481-4494 FAX (919) 460-3828