



OWNER'S MANUAL

CAD 300 SEI

Single-ended Integrated Stereo Amplifier

NOTE: Before installing your new component, please read this manual carefully as it will inform you of the product specifications, proper installation and correct operating procedures for your unit. Also included in this manual are guidelines on how to service and care for your new Cary Audio Design product.

TABLE OF CONTENTS

Introduction.....	3-4
Specifications	4-5
Features.....	6
Installation	7
Operation	8
Diagrams	9-11
Service and Care	11
Warranty	12

INTRODUCTION

Congratulations!

You have purchased one of the most exotic vacuum tube audio integrated amplifiers available. Within its power range, the CAD 300 SEI integrated amplifier offers the most realistic sound reproduction one could desire for a "high-end" home audio system. Careful design, parts selection and proper circuit topologies contribute to the incredible reliability and enjoyment.

For the technically minded, a review of the circuit is in order. Your new CAD 300 SEI operates in a class A single-ended mode utilizing an auto bias (cathode) system for the 300B triode output tubes. The input preamplifier section utilizes a 6SN7 dual triode tube. One triode section of this dual tube is used for the left channel and the other triode section is used for the right channel. This circuit is a Class A voltage gain circuit. This is the same basic first stage input circuit utilized in the Cary Audio model SLP 98 preamplifier. The next gain stage in the CAD 300 SEI utilizes a 6SN7 dual triode wired in a series constant-current plate-loaded configuration. This stage is duplicated for each channel. The series constant-current configuration then drives the 300B triode output stage in single-ended, class A. The output transformers in the CAD 300 SEI are the most important components in the amplifier and have been specifically designed by Cary Audio for use in the CAD 300 SEI. The output transformer is an air-gap design with a commercial continuous rating of 200% duty cycle. The CAD 300 SEI output transformer is an E/I laminate, silicon impregnated, grain oriented steel design. The windings are wax impregnated and the entire transformer is potted in high temperature wax. Utilizing the linear, directly heated filament-cathode 300B triode output tube, there is no global feedback used in the CAD 300 SEI. The power supply is a full wave center tap configuration running high voltage, high current fast switching diode rectifiers. The rectified 450 VDC is fed to a PI-L filter network. The filter capacitor consists of two (2) 1200 MFD and 230 Joules of energy storage. Each electrolytic capacitor is by-passed with a low impedance .22 polystyrene capacitor. The power transformer is a 200% duty cycle rating on the CAD 300 SEI. To avoid AC hum, both the 6SN7 and 300B tube have DC voltage on the filaments. This will prevent AC ripple voltage from capacitively being coupled to the elements in the tubes.

Additional Design Thoughts

A great deal of attention during the design of your new CAD 300 SEI was concentrated on the "overload recovery" ability of the amplifier to instantly recover from clipping and is a much more important issue than is commonly believed. In the power war of amplifier manufacturers the mentality is focused on high and then even higher power output to solve the clipping problem. When in reality, the most critical aspect is how fast a recovery an amplifier can achieve after overload. Most of the music being listened to in an average listening room is only requiring about 3 watts of power. It is on the transients of loud low frequency program material that tremendous signal voltages will appear at the input of the amplifier. It is in this situation that the overload recovery ability of an amplifier is of critical concern. The single-ended CAD 300 SEI extols its merits in the ability to handle transients and instantaneously recover from brief or even extended overloads. The CAD 300 SEI will overload symmetrically at any frequency in the audio band pass. The CAD 300 SEI will also yield faithful reproduction of extremely low frequencies at full output levels. Power transformer, power supply regulation and output transformer design and careful shaping of the overall frequency response curve all play a very important part in the ability of the CAD 300 SEI to recover quickly when overloaded. If one were to monitor the high voltage rail voltage (385 VDC at the anode of the 300B tube) of a CAD 300 SEI during soft and loud music passages it will be found there is no more than a volt or so change from soft to loud passages.

Another technical feature of your new CAD 300 SEI is amplifier stability. The CAD 300 SEI may be operated with no load (without speaker) without damage to the amplifier, output transformer or tubes. This is the hallmark of a high performance, STABLE, amplifier circuit design.

The most exciting feature of the CAD 300 SEI, aside from how compact and gorgeous it looks, is the delightful, sensual beauty of the music it recreates. The first thing that will strike you about your CAD 300 SEI integrated amplifier is the incredible transparency and resolution of detail of the music. The CAD 300 SEI sensual nature is best revealed in the sense of life it displays in female vocalists.

Your new CAD 300 SEI presents music with such presence and directness, you'll be drawn into the music hour after musically satisfying hour. This is the result of single-ended circuit techniques, which eliminate crossover notch at low levels and also contributes to the freedom from listening fatigue. The CAD 300 SEI will draw you in even further as you realize how lucid and utterly uncolored neutrality reveals delicate nuances in the sound stage.

Enjoy the music!

SPECIFICATIONS

This section describes the basic specifications of the CAD 300 SEI at the time of printing. Specifications are subject to change without notice or obligation. When the following cautionary terms are used in this manual, these definitions apply:

WARNING

Electrical hazard! Misuse or failure to follow instructions properly may result in personal injury or death!

CAUTION

No risk or personal injury; however, misuse or failure to follow instructions may result in damage to equipment.

NOTE

No risk of personal injury or equipment damage; however, misuse or failure to follow instructions may prevent proper performance of the equipment.

CIRCUIT TYPE	Single-ended, Class A
INPUTS	CD, AUX 1, AUX2
POWER OUTPUT	4/8 ohms = 15 watts/CH
S/N	90dB below rated power output

FREQUENCY RESPONSE	20 – 23,000 Hz (+0 – 0.75dB)
HEADPHONE OUTPUT	4-50 ohm compatible ¼" 3 circuit jack
POWER TRANSFORMERS	1 - EI laminated, 200% duty cycle
OUTPUT TRANSFORMERS	200% duty cycle Air gapped, wound with OFC copper wire, wax impregnated
RESISTORS	1% metal film
WIRE	Silver double "E" teflon
COUPLING CAPS	Oil filled
POWER SUPPLY CAPACITORS	2 – 1200mfd @ 450 VDC, Total – 2400 MFD – 230 Joules
WIRING	Point - to - point
LINE INPUT	3 switchable selections
SPEAKER POSTS	5-way Copper
TUBE SOCKETS	Ceramic with silver pins
ADDITIONAL FEATURES	Soft shoe feet Detachable power cord
TUBE COMPLIMENT	2 – 300B triode output tubes in Class A single-ended (CAVT 300B tubes) 1 – 6SN7 input tube 2 – 6SN7 driver tubes
WARM-UP TIME	3 minutes
BREAK-IN PERIOD	100 hours of music playing time
FINISH	Jaguar® medium blue chassis with black anodized aluminum front panel
DIMENSIONS	8" H x 14" W x 14" D
WEIGHT	42 lbs.

FEATURES

Front Panel

AC - ON SWITCH	Turns AC power on in the "UP" position
INPUT SELECTOR	Selection of line inputs for listening (CD, AUX1, AUX2)
VOLUME	Dual precision potentiometer controlling volume of both channels
BALANCE	Dual precision potentiometer to balance between left and right channels
HEADPHONE	3 conductor stereo headphone jack for headphones
OUTPUT SELECTOR	Switches amplifier output from speakers to headphones. When blue LED lights, the headphone jack is activated. (located on top right of chassis)

Rear Apron

INPUTS	Signal input connection via shielded interconnect cables
SPEAKER OUTPUT	High quality 5-way binding posts provide output to the speakers
POWER CORD	3 conductor shielded power cord to AC power mains
FUSE	AC power fuse. Never replace with any other fuse than 2 AMP SLOW BLOW! 250 VOLT
TUBE FUSE	Never replace with any other fuse than ¼ AMP FLAST BLOW!

CAUTION
EQUIPMENT DAMAGE MAY OCCUR WITH IMPROPER FUSES.
NEVER REMOVE / INSERT AC LINE CORD WHEN THE UNIT IS ON.

WARNING
MAKE NO ATTEMPT TO PUT THE CAD 300 SEI AMPLIFIER IN SERVICE WITHOUT THE BOTTOM
PLATE ATTACHED - CONTACT WITH VOLTAGE IN THE UNIT CAN BE FATAL!

INSTALLATION

This section describes the unpacking and installation procedures for your new component.

Unpacking

All Cary Audio Design shipping containers have been specially designed to protect their contents and special care has been taken to prevent damage under normal shipping conditions. Mishandling should be evident upon inspection of the shipping container. If shipping damage is found after visual inspection, take care not to destroy the evidence. If necessary, document the damage with photographs and contact the transport carrier immediately.

Carefully remove your new component from its packing carton and examine it closely for signs of shipping damage. We strongly recommend saving all original packing cartons to protect your amplifier from damage should you wish to store it or ship it for after-sales service.

Warranty Card

IN THE USA: If you are the original purchaser of a new unit from an AUTHORIZED CARY AUDIO DESIGN DEALER, please fill out the enclosed warranty registration card and return it to Cary Audio Design within 15 days of your purchase. Cary Audio Design also suggests that you keep your original packing cartons in case you ever need to ship the unit when moving to a new home. Warranty restrictions apply. Consult the warranty section at the end of this manual for details. Please be certain to keep a copy of the original sales receipt from your AUTHORIZED CARY AUDIO DESIGN DEALER to validate the warranty if ever needed. The warranty is for the original purchaser only and does not transfer to any subsequent owner.

OUTSIDE THE USA: Your local Authorized Cary Audio Design Distributor will make his own warranty policy for your country. Please check with them for the terms of warranty for your new amplifier.

Placement

In general, the location of your new CAD 300 SEI amplifier is not critical. The best placement in your system is near the speaker system with short lengths of speaker cables. Certain precautions must be taken to ensure optimum performance. Avoid extremely hot locations such as near radiator or other heating units. Keep the top of the CAD 300 SEI clear of books, paper or other equipment to protect against overheating.

Power Requirements

The CAD 300 SEI is designed to operate from house current mains. The design voltage is 117 VAC at 50/60Hz. (Foreign units 220 VAC at 50/60Hz.)

Cables

The speaker cables from the output posts of the CAD 300 SEI to the speaker system can be any convenient length your set-up requires. Select speaker cables of sufficient size to preserve the outstanding performance capabilities of your CAD 300 SEI. Heavy gauge #16 wire is suitable for distances up to 10 feet; #12 for 25 feet. Most audio dealers will have proper speaker cable in stock for this purpose.

OPERATION

Signal input connection is made via the input jacks on the rear of the CAD 300 SEI located next to the output binding posts. The interconnect cables from the output of the preamplifier can be any convenient length your set-up requires. The choice of a high quality interconnect cable is important. Once again, your audio dealer will have the proper cables in stock for this purpose.

Your new CAD 300 SEI is ready for operation after the speaker, interconnect cables, and the tubes have been installed. Refer to the tube placement sheet at the end of this manual for proper installation.

AC On Power Switch

Simply push the AC rocker switch on the ON position. Observe that the blue LED lights and all tubes are lit (filaments).

Break-In Period

The tubes, capacitors and output transformers take approximately 100 hours of music playing to fully settle in for peak performance. The CAD 300 SEI will sound good right out of the box and will improve with use. After the first couple of hours you will notice increased depth and tighter bass. This break-in period is true with vacuum tube based audio amplifiers.

Bias Adjustment Procedures

Look to the left rear corner of the CAD 300 SEI. You will notice a slotted screwdriver adjustment control. This is the bias adjust potentiometer. Also located in line with this control is a ¼" headphone style jack. This will accept the included orange/black test cable. These two leads will hook to a DC current meter or digital multimeter.

1. Make sure the CAD 300 SEI is in the off position with all the tubes inserted into the proper sockets.
2. Plug in the two-conductor test cable into the ¼" jack. Clip the black alligator clip to the black negative lead on your multimeter. Hook the red alligator clip to the red positive lead from the multimeter.
3. Place the multimeter range selector in the DC current range. This may say 0 – 300 mA. Just make sure you are reading DC current. Never select the DV voltage position. Only the DC current scale.
4. Locate a proper flat blade screwdriver that fits the slot on the bias adjustment control.
5. With your CAD 300 SEI plugged into the house AC mains wall socket turn on the AC power switch. Immediately observe the DC current reading. The proper value will be 150 to 160 mA.
6. If the value is low, turn the bias control clockwise (right) a small amount. If the current reads higher than 160 mA. Turn the bias adjustment control counter clockwise (left).
7. After the 300 SEI has been on for about ten minutes recheck the bias and reset to 150 to 160 mA Range. This completes the bias setting. You may wish to check this setting every six months or so. Please note that the bias will vary as your AC line voltage moves up and down in your home. This is normal. The amplifier will operate in a broad range of 120 mA to 180 mA of current. The value of 150 to 160 is the ideal point.
8. Turn off your CAD 300 SEI and remove the test cable and store this cable in a convenient location in your listening room.

WARNING

MAKE SURE AMPLIFIER IS UNPLUGGED FROM AC MAINS BEFORE SERVICING.

300sei Bias Adjustment

Adjust bias pot until meter read 160mA

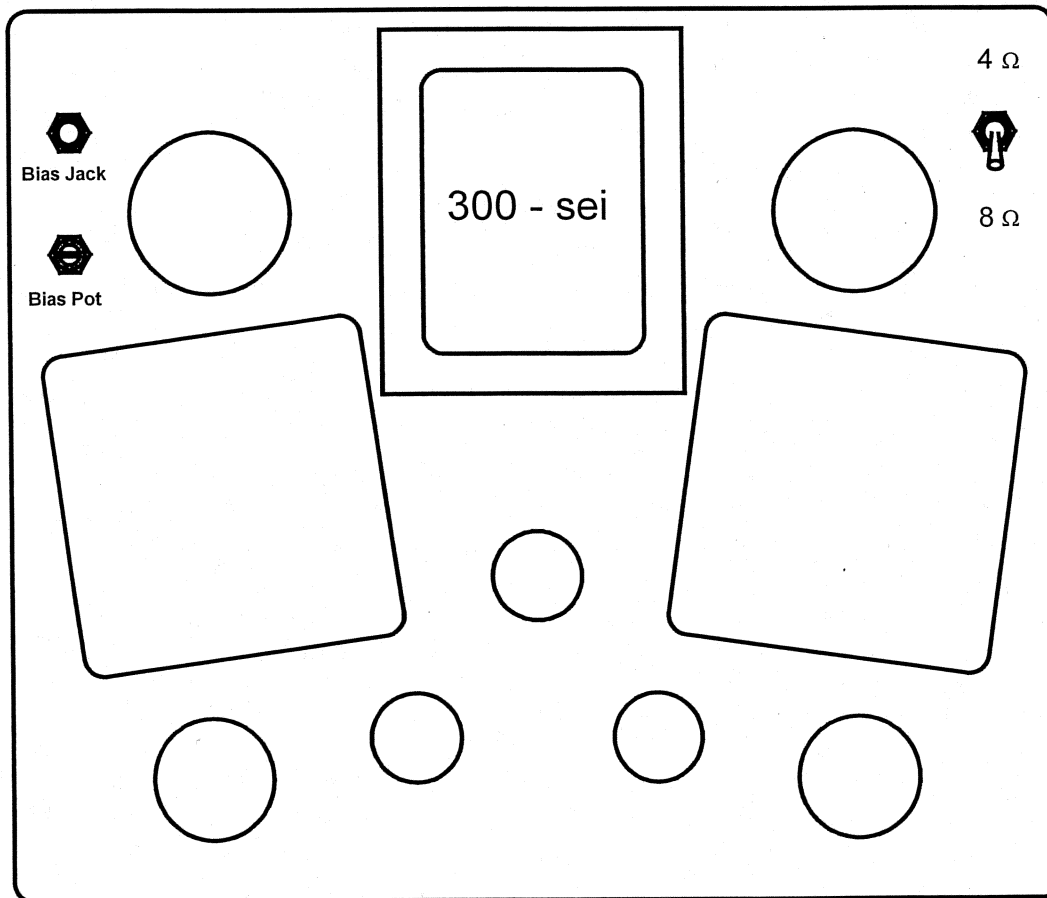
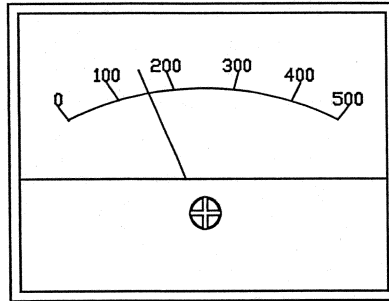
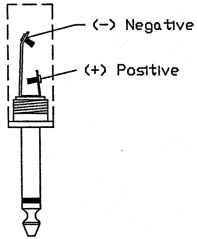

Insert the meter plug into the bias jack. Adjust for 150 mA to 160mA reading on volt ohm meter or DC current meter. Readjust the setting after the amp has warmed up for 10 minutes. Remove the bias adjustment plug and enjoy the music!

300B
TUBE

THIS SIDE OF TUBE
CHIMNEY SHOULD FACE
TO THE FRONT

PRINT SHOULD FACE
TO THE FRONT

LARGE PINS TO
LARGE HOLES IN
SOCKET FRONT

IMPORTANT! IMPORTANT!

THE TWO LARGE PINS ON THE BASE
OF THE 300B TUBES MUST FACE
THE FRONT OF THE CAD-300 AMPLIFIER!!

AMPLIFIER FRONT

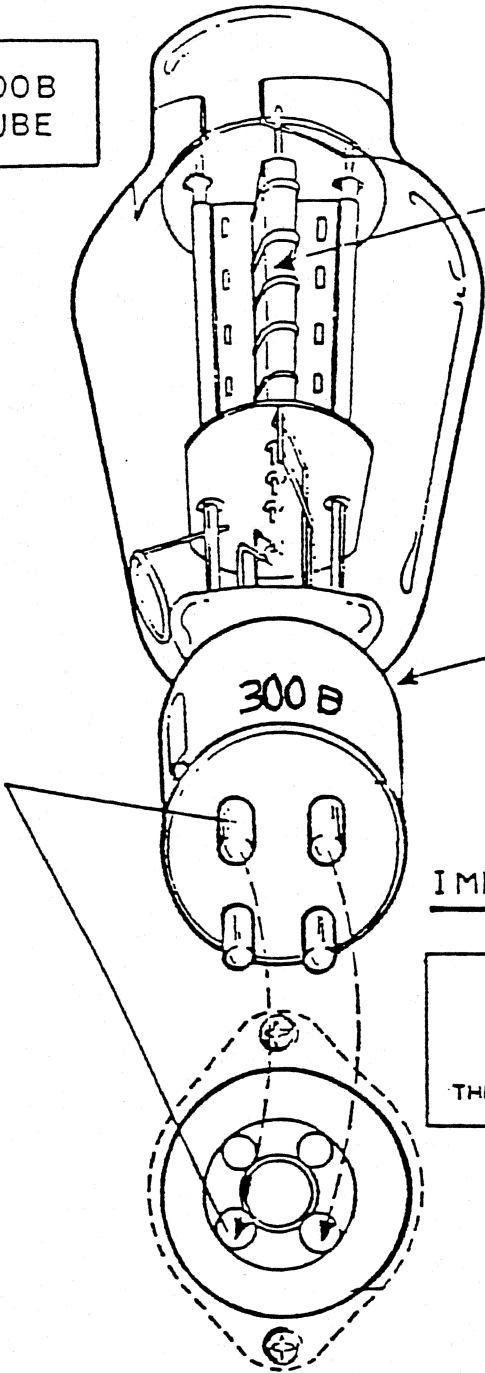

Tube Placement Chart

CAUTION

Large pins on the 300B output tubes must be inserted into the large holes in the tube socket. Failure to follow these instructions will result in serious damage to the tubes and amplifier and is not covered by the manufacturer's warranty.

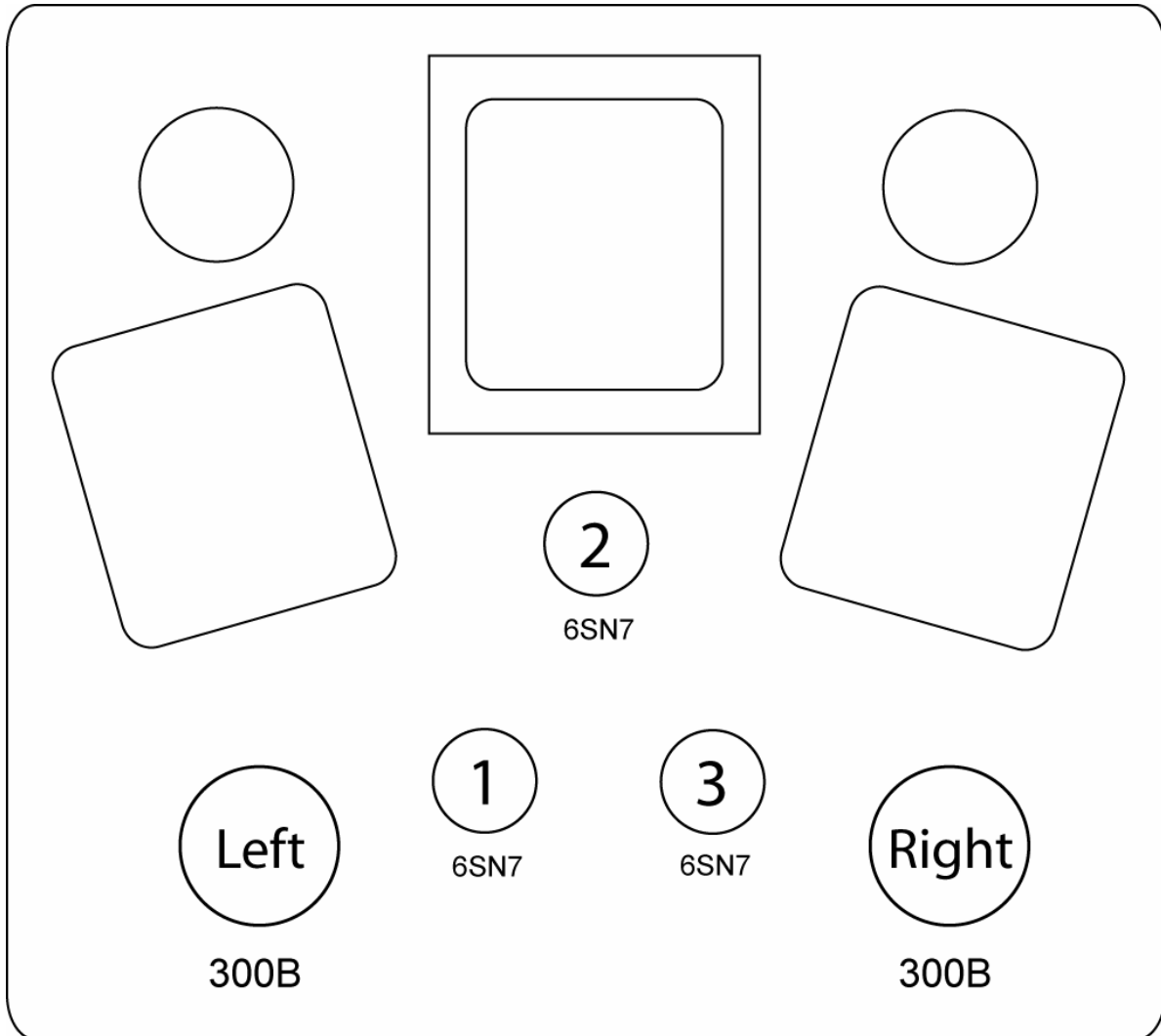

SERVICE AND CARE

The chassis may be cleaned with a soft towel and Windex® or a similar window cleaner. Spray it on the cleaning cloth to moisten it, not on the component. Do not use solvents or harsh chemicals to clean the preamplifier. They may remove the labels from the chassis. The frequency and need of cleaning will be governed by operating environmental conditions. Avoid letting the component become dusty or wet. A 'feather duster' type cleaner will also work well for cleaning the component.

Tube Replacement

If it becomes necessary to replace the tubes in the CAD 300 SEI amplifier, a matched set of output tubes of the same brand should be used. A new tube kit is available from Cary Audio Design. You should get a few years or more from the output tubes with everyday usage and many, many years of use from the 6SN7 input tube and 6SN7 driver tubes.

Factory Service

Careful consideration has been given to the design of this product to keep maintenance problems to a minimum. If the problem is not easily solved, we suggest that you contact our Customer Service Department by phone at (919) 355-0010, 1–5 pm Eastern Standard Time, to describe your problem in detail. DO NOT return the component to the factory without a Return Authorization Number (RA) from the Customer Service Department.

Cary Audio Design assumes no responsibility if the transportation company refuses to pay a damage claim due to your improper packing or lack of insurance should the unit be lost in shipment. We strongly suggest using the original packing cartons for shipping any Cary Audio Design component.

Non-Warranty Repairs

Cary Audio Design will provide repair service for its products charging on a time and expense basis. At this time, the standard non warranty service bench fee is \$125 with all parts used for repair charged extra. This may change with time and is not a quote for service. Please call us at 919-355-0010 for more information about out of warranty service and repair fees.

WARNINGS

MAKE NO ATTEMPT TO PUT THE CAD 300 SEI IN SERVICE WITH THE BOTTOM PLATE REMOVED. CONTACT WITH HIGH VOLTAGES FOUND IN THE UNIT CAN BE FATAL. COMPLETELY REMOVE AC POWER PLUG FROM THE WALL AND ALLOW 30 MINUTES FOR THE HIGH VOLTAGE CAPACITORS TO DISCHARGE THROUGH BLEEDER RESISTORS BEFORE ATTEMPTING TO CHANGE TUBES OR CLEAN THE INSIDE OF THE AMPLIFIER.

CAUTIONS

NEVER REMOVE / INSERT AC PLUG WHEN THE UNIT IS ON OR THE AC POWER SWITCH IS IN THE ON POSITION. OBSTRUCTION OF THE TOP PORTION OF THE CAD 300 SEI WILL RESULT IN TUBES OVERHEATING.

UNITED STATES LIMITED WARRANTY

Cary Audio Design warrants to the original United States purchaser for use in the United States that Cary Audio Design vacuum tube or solid state power amplifiers, surround sound processors or preamplifiers shall be free from defects in parts or workmanship for three (3) years from the date of the original purchase. Vacuum tubes, if any are used in the component, are offered a 90 day from purchase date exchange policy against defects with the exception of the CAVT 300B vacuum tube which has a (1) one year from purchase date exchange policy. Any digital drive design, whether a Cary Audio Design CD or SACD player or a Cary Cinema DVD player, has a limited one year parts and labor warranty against defects in manufacture. This is a limited warrant, for the original purchaser only and does not transfer to any subsequent owner. During the limited warranty period, Cary Audio Design or an authorized Cary Audio Design service facility will provide free of charge both parts and labor necessary to correct any defects in material or workmanship.

To obtain such warranty service, the original purchaser must:

1. Complete and send in the warranty Registration Card within 15 days of purchase.
2. If claiming service the owner must send a fully filled in copy of the original sales receipt along with any unit sent in for service showing the AUTHORIZED CARY AUDIO DESIGN DEALER'S name, the new selling price, the buyer's name, e-mail or phone number and address on the receipt. Blank receipts will NOT validate the limited warranty for service.
3. Notify Cary Audio Design as soon as possible after the discovery of a possible defect and submit the following information to determine eligibility for warranty:
 - (a) The model number and serial number;
 - (b) A fully filled in copy of the original sales receipt showing the original selling price, purchasers name and address filled in by an AUTHORIZED CARY AUDIO DESIGN DEALER with the original date of purchase shown on the form;
 - (c) a detailed description of the problem.
4. Deliver the product to Cary Audio Design or the nearest authorized service facility or ship with all freight and insurance charges prepaid, in its original packing container or equivalent, to Cary Audio.

Correct maintenance, repair and use are important to obtain performance from this product. Therefore, please carefully read the Operating Manual. This warranty does not apply to any defect that Cary Audio Design in its sole discretion determines is due to:

1. Improper maintenance or repair, including the installation of parts or accessories that do not conform to the quality and the specifications of the original parts.
2. Misuse, abuse, neglect or improper installation.
3. Accidental or incidental damage.

WARRANTY DISCLAIMER

Except for the express warranties stated herein, Cary Audio Design disclaims all other warranties including, without limitation, all implied warranties of merchantability and fitness for a particular purpose. The foregoing constitutes Cary Audio Design's entire obligation with respect to this product, and the original purchaser and any user or owner shall have no other claim for incidental or consequential damages. Some states do not allow the exclusion or limitation of incidental or consequential damages, so the above limitation and exclusion may not apply to you. This warranty gives legal rights and you may also have other rights, which vary from state to state.

EXCLUSIVE REMEDY

Notwithstanding the foregoing, the purchaser's exclusive remedy for any breach of warranty, express or implied, is limited to the repair or replacement of the defective unit or the refund of the purchase price, at the option of Cary Audio Design. Under no circumstances is Cary Audio Design liable for incidental or consequential damages. Any implied warranties imposed by law terminate one (1) year from the date of purchase.

INTERNATIONAL PURCHASERS (Export markets)

Cary Audio Design warrants its merchandise to purchasers within the United States exclusively for use within the United States of America. It provides no other warranties, expressed or implied. If you are living outside the USA, please consult with your local dealer or distributor to determine the details of your local warranty.

CARY AUDIO DESIGN

1020 Goodworth Drive, Apex, NC 27539
phone 919-355-0010
fax 919-355-0013
www.caryaudio.com

